

**OSE S.A. - DEVIATION OF THE CITY OF CORINTH**  
**HIGH SPEED RAILWAY LINE**  
**RAILWAY BRIDGE OVER THE CORINTH ISTHMUS AT CHAINAGE 89+298.84**

PROJECT BUDGET: 7.710.500 €  
CONSTRUCTION: MECHANIKI S.A. (2003-2005)  
DESIGN: ODOMECHANIKI Ltd - KANON CONSULTING (2002-2003)

As pictured below, the railway bridge comprised a continuous superstructure with a total length of 230.0m. The bridge connected the two sides of the Corinth Isthmus, allowing a free height of 52.0m for the passage of vessels. Our firm was responsible for designing the superstructure, while the design of the foundation and piers was the subject of a separate, specialized study.

Constructed via the balanced cantilever method, the bridge deck was continuous and had three spans: 60.0 - 110.0 - 60.0m. The deck cross section was a single cell box 6.60m wide with variable height (11.0-5.0m). Combined, the two cantilevers made up a maximum width of 12.0m. The superstructure of the bridge was supported by piers using a "partial" seismic isolation system; this system was capable of absorbing a significant part of the seismic design energy, in order to allow displacements and forces at the pier top level to be reduced to sustainable limits. We have referred to the seismic isolation system as "partial" because the transverse displacement of the superstructure at the abutments was prevented through stoppers, thus preventing discontinuities in the rails. In addition, the "partial" seismic isolation system was comprised of special requirement bearings placed at all piers.

Using conventional framework for the bridge construction, our firm cast two end spans and parts of the middle spans; the remaining part of the central span was constructed via the balanced cantilever method.



***Construction of Bridge over the Corinth Isthmus using the balanced cantilever method***

The two middle piers - M1 and M2 - were comprised of 2.0x5.0m box sections with a capping section 3.0x7.0m on top and a height of 12.0m. Piers M1 and M2 were founded by deep concrete wells 6.0m diameter 22.0m long and 7.0m diameter 25.0m long, respectively.

In order to sustain the horizontal forces, the foundation of each of the middle piers was reinforced by the construction of a grid of piles, with dimensions measuring at 9.50x9.50x1.50m. The grid consisted of nine piles which were 1.50m in diameter and 15.0m long.

The height measurements of abutments A1 and A2 were 8.50m for A1 and 7.50m for A2. In addition, they were founded by 6.0m diameter deep concrete wells: 12.0m and 17.0m long for abutments A1 and A2 respectively.



**The construction of the Bridge over the Corinth Isthmus is completed**

Special seismic and geological studies were performed to assist the bridge design and determine the magnitude of potential tectonic movement between the two sides of the canal. In particular, the seismic isolation system was tested at the University of Buffalo in New York, U.S.A.

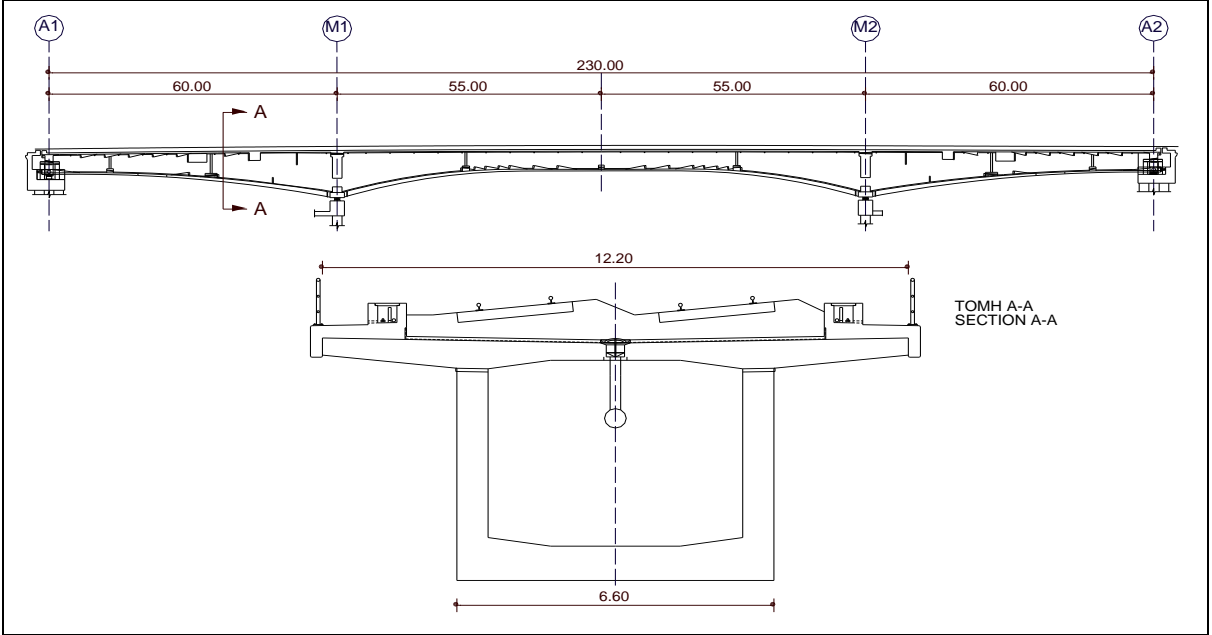

**Longitudinal section and cross section of Bridge over the Corinth Isthmus**